

Manual / Start-Up Guide L-LAS-TB-...-AL-SC Spray Control System

with

L-LAS-Spray-Control Scope V2.1

(PC software for Microsoft® Windows 10)

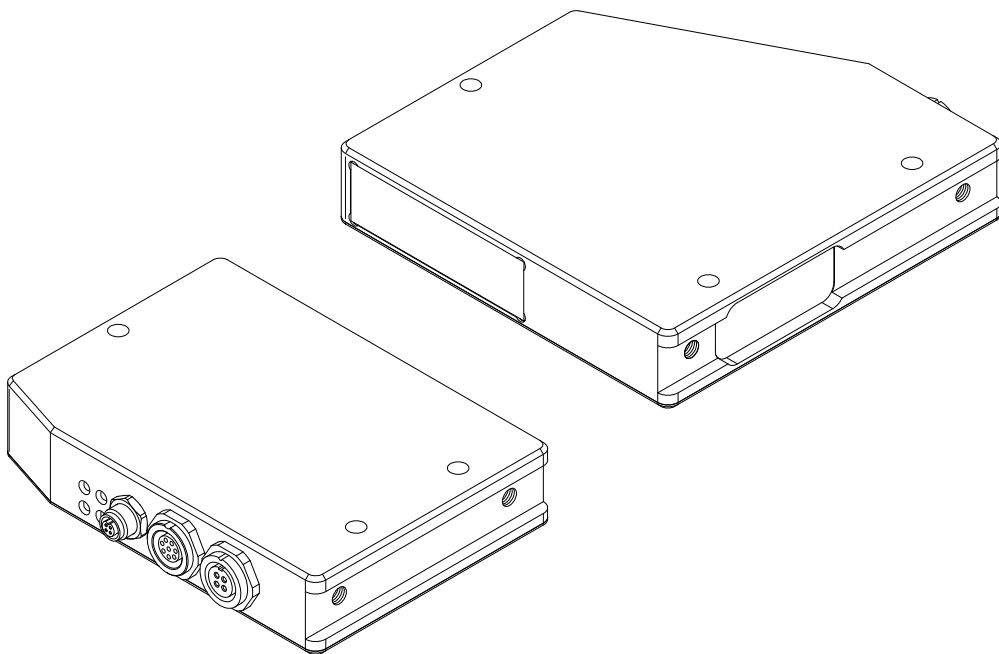

0 Contents

0	CONTENTS	2
1	FUNCTIONAL PRINCIPLE OF THE L-LAS-TB-... LASER LINE SENSOR.....	3
1.1	Technical description	3
2	INSTALLATION OF THE L-LAS-SPRAY-CONTROL SOFTWARE	4
3	CONTROL ELEMENTS OF THE L-LAS-SPRAY-CONTROL-SCOPE SOFTWARE	5
3.1	Short description of the <i>L-LAS-Spray-Control-Scope</i> user interface:.....	5
3.1.1	VIDEO/NORM Display-Elements.....	6
3.1.2	PARA Parameter Settings	7
3.2	Procedure for start-up:.....	9
3.2.1	Adjusting transmitter and receiver	9
3.2.2	Establishing power supply / PLC connection.....	9
3.2.3	Connecting the RS-232 interface.....	10
3.2.4	Adjusting the laser power / white balancing.....	12
3.2.5	Recording of spray events	13
3.2.1	Working with the teach table.....	14
3.3	Procedure for measuring with the PLC.....	17
3.3.1	WHITE BALANCE.....	18
3.3.2	START / TRIGGER MEASUREMENT.....	19
3.4	Carrying out the measurement system analysis (MSA)	20
3.3.1	Step1: Checking the intensity curve (RAW).....	21
3.3.2	Step2: Checking the WHITE-BALANCING.....	21
3.3.3	Step3: Start of the MSA	22
4	ANNEX	23
4.1	Display elements.....	23
4.2	Function of digital input IN0, IN1.....	23
4.2.1	PLC connection: WHITE-BALANCE procedure	23
4.2.2	PLC connection: Trigger Spray-Event	24
4.3	Laser warning	25
4.4	RS232 interface protocol	26
4.4.1	ORDER=5: ECHO-CHECK, READ LINE OK of sensor	28
4.4.2	ORDER=7: Lese FIRMWARE-VERSIONS-STRING von Sensor	28
4.4.3	ORDER=8: Get MEASURED-VALUES from L-LAS sensor	29
4.4.4	ORDER=9: Get DATA BUFFER from L-LAS sensor.....	30
4.4.5	ORDER=11: Activate SINGLE SHOT MEASUREMENT at L-LAS sensor.....	31
4.4.6	ORDER=12: Activate WHITE BALANCE PROCEDURE at sensor	31
4.4.7	ORDER=12: Activate EVALUATION PROGRAM at L-LAS sensor	32
4.4.8	ORDER=26: Send TEACH VECTOR ENTRY to L-LAS sensor.....	33
4.4.9	ORDER=30: Activate Measurement-System-Analysis (MSA) at L-LAS sensor.....	34

1 Functional principle of the L-LAS-TB-... laser line sensor

1.1 Technical description

In the laser line sensors of the *L-LAS-TB-... series* the laser beam of a laser diode ($\lambda=670\text{nm}$, 0.4mW opt. power, laser class 1) through suitable collimators and apertures is emitted from the optical transmitter unit as a laser line, i.e. as parallel laser light with homogeneous light distribution. In the optical receiver unit the laser line impinges on a CMOS line receiver. This CMOS line comprises many closely adjacent individual receiver elements (pixels) that are arranged in a line. The light quantity of each of these receiver elements that is collected during the integration time is separately read out as an analog voltage (video signal) and, after analog/digital conversion, is stored in a data field as a digital value.

With spray control using the light band method, the parallel laser light is continuously directed onto the spray jet. The light band is usually wider than the diameter of the spray cone, so the spray jet is completely covered. The CMOS line detector enables a complete evaluation of the beam profile. During the spraying process, individual pixel areas on the receiver are more heavily dampened. To determine the beam profile, a white balance (referencing) is carried out before the measurement. Using suitable software algorithms, the reference signal is constantly compared with the current video image during the spraying process. In this way, a spray density profile over time and the spray quantity can be determined by evaluating the area and height of the video image. The microcontroller of the L-LAS-...-SC control electronics can be parameterized using *Windows®* PC software via the serial RS232 interface. Various evaluation modes can be set. A total of up to 16 programs that can be stored in a learning table are available for evaluation. The switching states are visualized via four LEDs (1x green, 1x yellow and 2x red), which are integrated in the housing of the L-LAS-...-SC sensor. The L-LAS-...-SC control electronics has three digital outputs (OUT0, OUT1, OUT2) whose output polarity can be set via software. An external TRIGGER functionality and the white balance procedure can be triggered by a PLC via two digital inputs (IN0=EXT-TRIG, IN1=WHT-BAL). Furthermore, an analog output (0 ... 10V) with 12-bit digital/analog resolution is provided, which is controlled proportionally to the spray density.

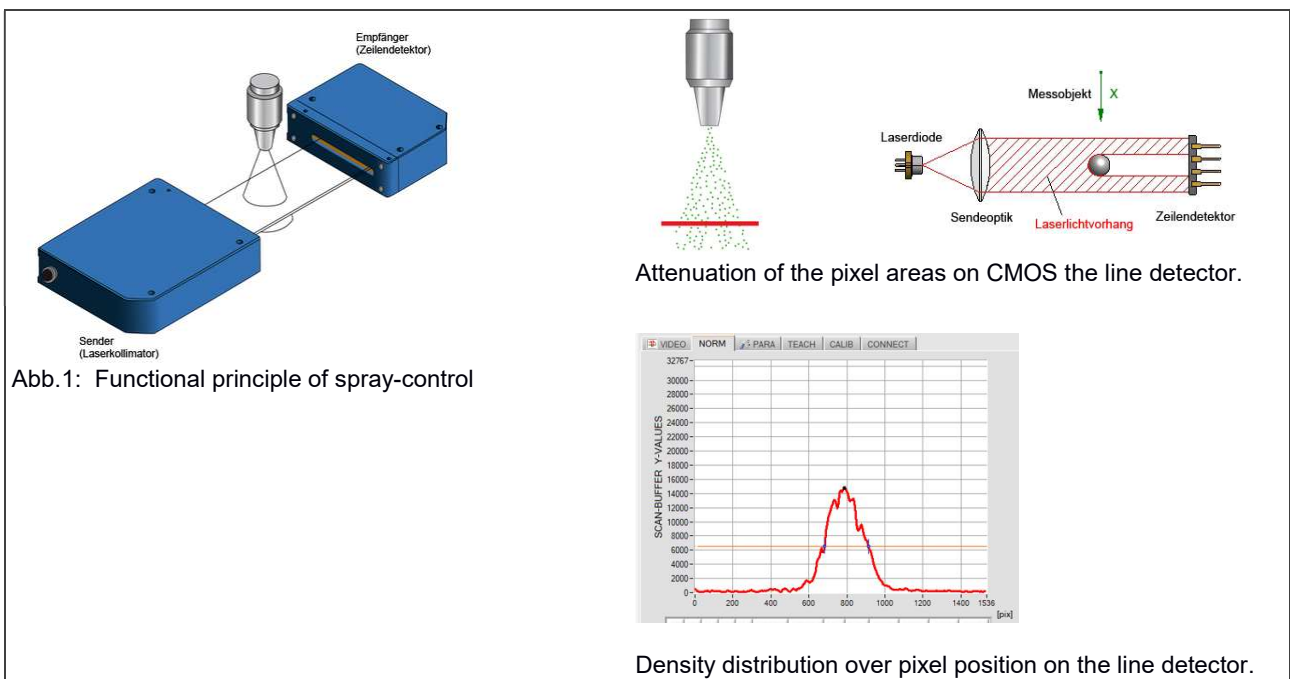

2 Installation of the *L-LAS-Spray-Control* software

Hardware requirements for successful installation of the *L-LAS-Spray-Control-Scope* software:

- Microsoft® Windows® 7, 8, 10
- IBM PC AT or compatible
- VGA graphics
- Microsoft-compatible mouse
- Serial RS232 interface at the PC or USB slot or RJ45 connector
- Cable cab-las4/PC for the RS232 interface or cab-4/USB USB converter or cab-4/ETH Ethernet converter

Please install the *L-LAS-Spray-Control-Scope* software as described below:

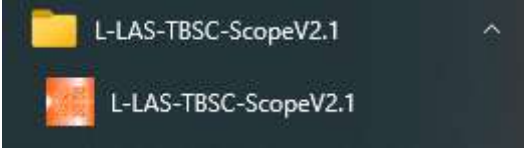
1.	The software can be installed directly from the installation DVD. To install the software, start the SETUP program in the SOFTWARE folder of the DVD.
2.	<p>The installation program displays a dialog and suggests to install the software in the C:\'"FILENAME"\' directory on the hard disk.</p> <p>You may accept this suggestion with OK or [ENTER], or you may change the path as desired. Installation is then performed automatically.</p>
3.	<p>During the installation process a new program group for the software is created in the Windows Program Manager. In the program group an icon for starting the software is created automatically. When installation is successfully completed the installation program displays "Setup OK".</p>
4.	<p>The <i>L-LAS-Spray-Control-Scope</i> software can now be started by clicking on the respective icon in the newly created program group under:</p> <p>Start >All Programs > <i>L-LAS-TBSCl-ScopeV2.0</i></p> <div style="border: 1px solid black; background-color: #333; color: white; padding: 5px; margin: 5px 0;">  </div>

Uninstalling the *L-LAS-Spray-Control-Scope* software:

 Programme und Funktionen	<p>Please use the Windows® uninstall tool to remove the software. The Windows® uninstall tool can be found under</p> <p>Start / Settings / Control Panel.</p>
--	---

3 Control elements of the *L-LAS-Spray-Control-Scope* software

3.1 Short description of the *L-LAS-Spray-Control-Scope* user interface:

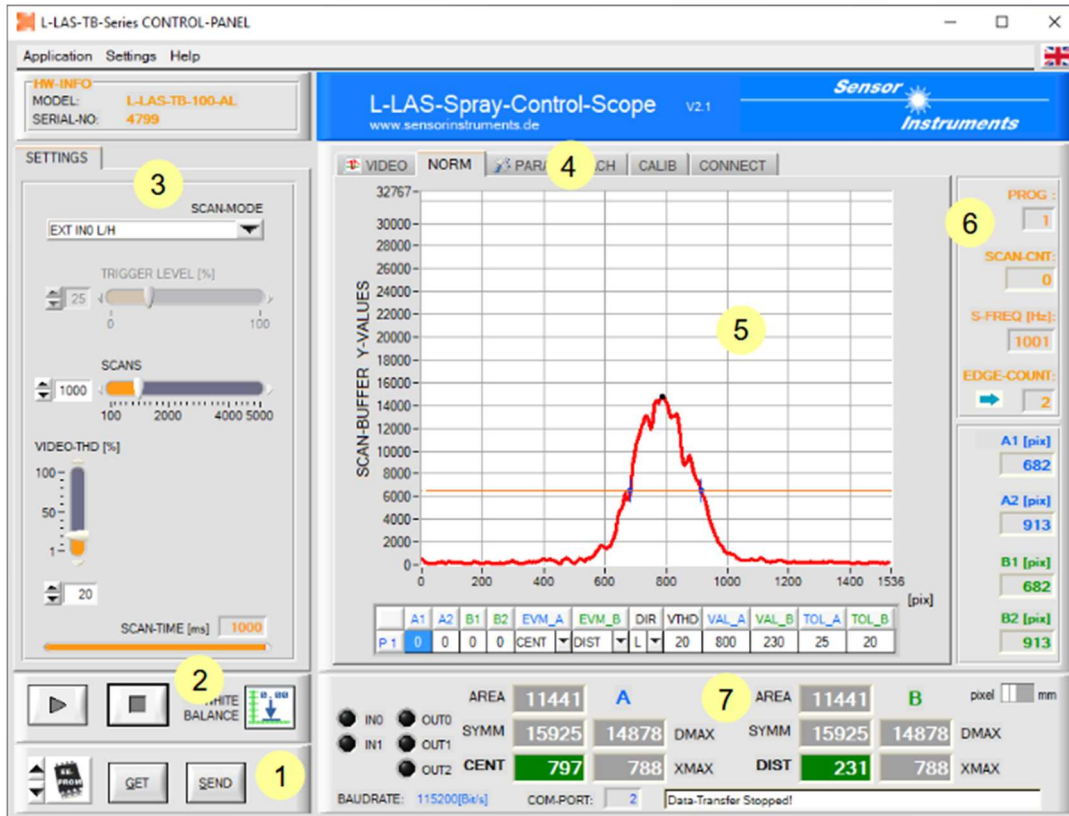

The *L-LAS-Spray-Control-Scope* user interface provides a great variety of functions:

- Visualization of measurement data in numeric and graphic output fields.
- Setting of the light source.
- Setting of the polarity of the digital switching outputs OUT0, OUT1, OUT2
- Selection of a suitable evaluation mode.
- Saving of parameters to the RAM, EEPROM memory of the control unit, or to a configuration file on the hard disk of the PC.

- 1 Function fields for sending / reading the setting parameters (parameter transfer).
- 2 START / STOP function fields for the RS232 data exchange with the sensor.
- 3 Presetting of current parameters at the sensor (trigger mode, evaluation threshold...).
- 4 Tab row to switch between different tab graphic windows.
- 5 Graphic output (display of the measured value over time, with teach value and tolerance band).
- 6 Numeric display elements (measuring frequency, number of edges, program number, ...).
- 7 Measured value display in [mm] or [pixel].

The following chapters provide explanations of the individual control elements of the *L-LAS-Spray-Control-Scope* software. Pressing the right mouse button on an individual element will call up a short help text.

3.1.1 VIDEO/NORM Display-Elements

VIDEO Display:

The VIDEO display is used to show the current video signal of the line sensor of the receiver unit. The video signal represents the analog intensity over the respective pixel element of the line sensor.

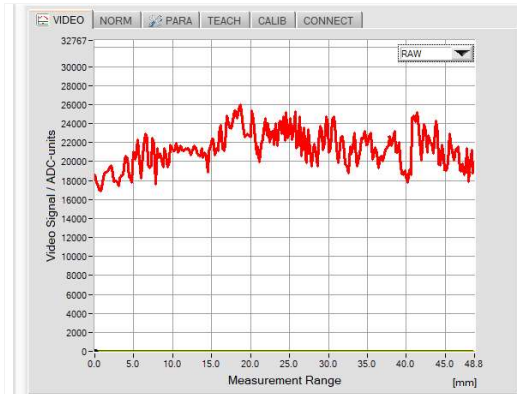

RAW:

After clicking the [>] RUN button, the current intensity profile of the raw data of the laser beam is displayed over the measuring range.

The intensity curve (RAW) over the active area (pixel) of the line sensor must be in the range of 30% to 90% of the dynamic range.

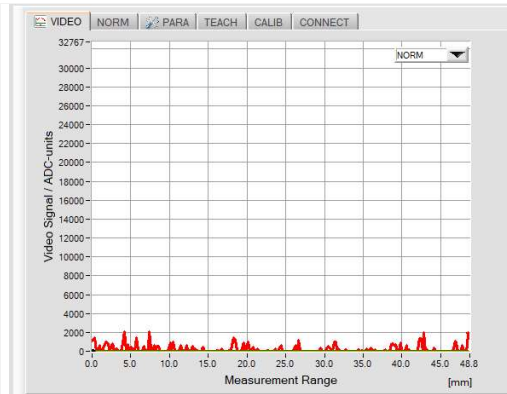

NORM:

After clicking the [>] RUN button, the normalized intensity curve (after WHITE BALANCING) is displayed over the measuring range.

If no spray process is active, the normalized intensity should be below 10% of the dynamic range.

NORM Display:

The NORM display is used to show the standardized evaluation of the spraying process on the line sensor. The spray-density profile recognized over the set measuring period is displayed over the measuring range.

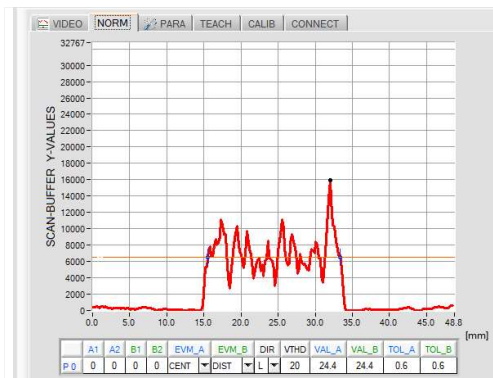

After clicking the [>] RUN button, the current spray density curve is displayed over the measuring range.

3.1.2 PARA Parameter Settings

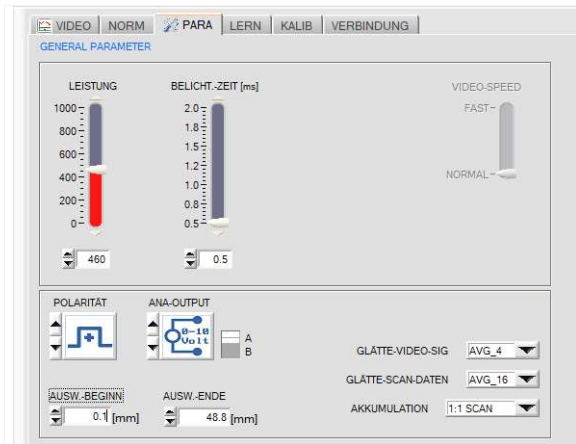

PARA tab:

After clicking on PARA, the GENERAL PARAMETER window opens on the user interface. Various setting and evaluation parameters can be specified here on the *L-LAS-TB-SC control electronics*.

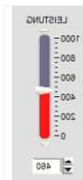

POWER:

In this function field, the power of the laser transmitter unit on the *L-LAS-SC... sensor* can be set with the aid of the arrow keys, slide controls or by entering numerical values in the corresponding input field. The laser power should be set so that the RAW video signal (intensity curve) over the active surface of the receiver (line sensor) is in the range of 30% to 90% of the maximum dynamic range.



EXPOSEURE TIME:

In this function field, the exposure time on the *L-LAS-SC sensor* can be set with the help of the arrow keys, slide controls or by entering numerical values in the corresponding input field. The exposure time should be set so that the RAW video signal (intensity curve) over the active surface of the receiver (line sensor) is in the range of 30% to 90% of the maximum dynamic range.

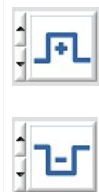

POLARITY:

Setting the polarity at the digital outputs OUT0, OUT1 und OUT2.

- [+] **DIRECT:** In the event of an error, the digital output is at + U_b (+ 24VDC), the LED for displaying the digital out status lights up red.
- [-] **INVERSE:** In the event of an error, the digital output is at GND (0V) potential, the LED for displaying the digital out status lights up red.



ANALOG AUSGABE:

0-10Volt: Analog voltage output 0..10V /pin8/ M12 SPS plug

4 – 20mA: Current output 4 - 20mA /pin7/ M12 SPS plug

A / B: Toggle switch for specifying which evaluation (A or B) is to be output at the analog output.

SMOOTH-VIDEO-SIG <input style="width: 80px;" type="text" value="AVG_4"/>	<p><u>SMOOTH-VIDEO-DATA:</u> A smoothing of the video signal can be set in this list function field. The intensity curve (RAW) of the video signal is subjected to a "moving average calculation" before the edge search. This can be helpful for suppressing interference signals on the video signal. The size of the ring buffer can be set between AVG = 1 and AVG = 64.</p>
--	--

SMOOTH-SCAN-DATA <input style="width: 80px;" type="text" value="AVG_16"/>	<p><u>SMOOTH-SCAN-DATA:</u> In this list function field, the data buffer of the recorded SCAN data (spray density curve) can be smoothed. The data buffer is subjected to a "moving average calculation". This can be helpful for suppressing disruptive artifacts in the spray density curve. The size of the ring buffer can be set between AVG = 1 and AVG = 64.</p>
---	---

ACCUMULATION <input style="width: 80px;" type="text" value="1:1 SCAN"/>	<p><u>ACCUMULATION:</u> The accumulation of the spray density SCAN data can be set in this list function field.</p> <p>1: 1 SCAN: In the main program run, each individual data buffer is used to determine and evaluate the spray density.</p> <p>2_SCANS: In the program sequence, the spray density profile is added up over 2 main program runs and then subjected to an evaluation. * *</p> <p>N_SCANS: In the program sequence, the spray density profile is added up over N main program runs and then subjected to an evaluation.</p> <p>The number N can be set between 1-SCAN and 64-SCANS. By increasing the accumulation, finer spray densities can be detected, the scanning frequency of the sensor is reduced by a factor of 1 / N.</p>
---	--

EVAL-BEGIN <input style="width: 80px;" type="text" value="0.1 [mm]"/>	<p><u>EVAL-BEGIN:</u> By entering numerical values in the numerical input field or by clicking the arrow keys, the start of the measuring range (SMR) for the edge search on the spray density curve can be specified in [mm] or [pixels].</p>
---	--

EVAL-END <input style="width: 80px;" type="text" value="48.8 [mm]"/>	<p><u>EVAL-END:</u> By entering numerical values in the numerical input field or by clicking the arrow keys, the end of the measuring range (EMR) of the edge search can be specified in [mm] or [pixels] on the spray density curve.</p>
--	---

3.2 Procedure for start-up:

3.2.1 Adjusting transmitter and receiver

The L-LAS transmitter and receiver should be optimally aligned to each other, which should be done by means of a traverse or by way of fixed mounting of transmitter and receiver.

3.2.2 Establishing power supply / PLC connection



There are three connecting sockets at the housing of the *L-LAS-TB-...-AL-SC control unit (receiver unit)*.

A 4-pole M5 socket type Binder 707 is used to connect the serial RS232 interface.

An 8-pole M9 socket type Binder 712 is used to connect the sensor with the PLC / power supply.

A 4-pole M9 socket type Binder 712 is used to connect the *L-LAS-TB-...-AL-SC transmitter unit*.

8-pole female connector type Binder 712



Connecting cable: cab-las8/SPS (standard length 2m, cable sheath: PUR)

Pin	Color	Assignment
		L-LAS-TB-...-AL-SC (control unit)
1	White	0V (GND)
2	Brown	+24 VDC \pm 10%
3	Green	IN0 (EXT TRIGGER)
4	Yellow	IN1 (WHT BALANCE)
5	Grey	OUT0 (BUSY)
6	Pink	OUT1 (ERR EVAL A)
7	Blue	OUT2 (ERR EVAL B)
8	Red	Analog (voltage 0...+10V or current 4...20mA)

3.2.3 Connecting the RS-232 interface

4-pole female M5 connector type Binder 707

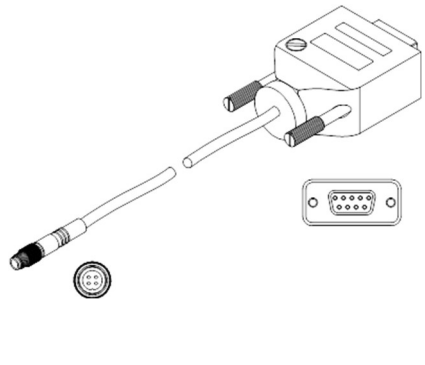
Connecting cable: cab-las4/PC (standard length 2m, cable jacket: PUR), also available: cab-4/USB, cab-4/ETH-500

	Pin	Assignment
	L-LAS-TB-...-AL-SC (control unit)	
	1	+Ub
	2	0V (GND)
	3	RxD
4	TxD	
		

Establishing the connection through PC-RS-232:

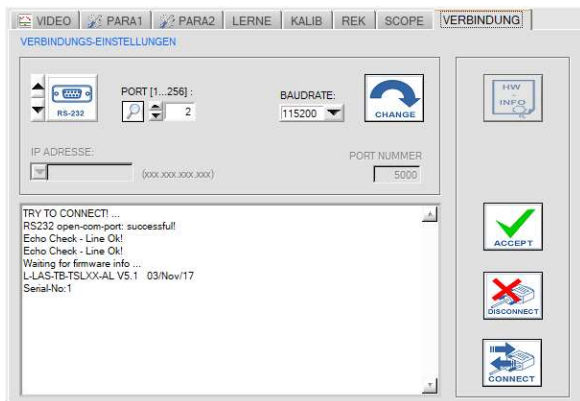

CONNECTION tab:

Click on this tab to open the CONNECTION window, where you can set various parameters for data exchange through the serial RS232 interface.

Basically the following default values are used for communication:

- Standard RS232 serial interface, no hardware handshake
- 3-wire-connection: GND, TXD, RXD
- Baud rates from 9600 baud to 115200 baud
- 8 DATA bits, 0 PARITY bit, 1 STOP bit
- Highest-order byte first (MSB first)
- **Standard baud rate = 115200 baud**

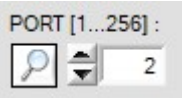

PORT [1...256]:

The number of the communication port can be set in this function field. Possible values are COM 1 to 255.

The communication port number can be found in the Windows® operating system under START/Control Panel/Device Manager.

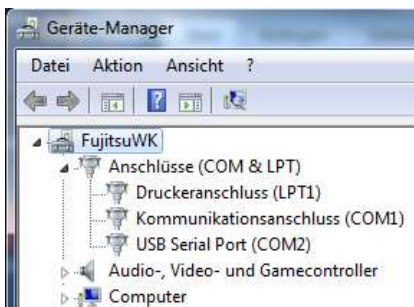

As an alternative the communication port numbers that are available on the PC can be searched by clicking on the magnifier symbol.

The available COM ports are displayed in the status text field.

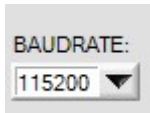

BAUDRATE:

The baud rate of the serial interface can be set in this function field:

Possible values: 9600 baud, 19200 baud, 38400 baud, 57600 baud, 115200 baud, 230600 baud, 460800 baud or 921600 baud. (**Setting when delivered = 115200 baud**).



CONNECT:

When you click on this button, the system attempts to establish a connection to the sensor with the set communication parameters. Feedback about the progress of connection establishment is shown in the status display field.



DISCONNECT:

Click on this button to disconnect the connection with the sensor. The opened communication port becomes free again.



ACCEPT:

When you click on the ACCEPT button, the current communication settings are saved in the *TB-Scope.ini* file. When the *L-LAS-Spray-Control-Scope* software is started again, communication is established with the parameters saved in the *TB-Scope.ini* file.

3.2.4 Adjusting the laser power / white balancing

Prerequisite: Successfully established connection ->> corresponding status line is displayed in the CONNECT tab.

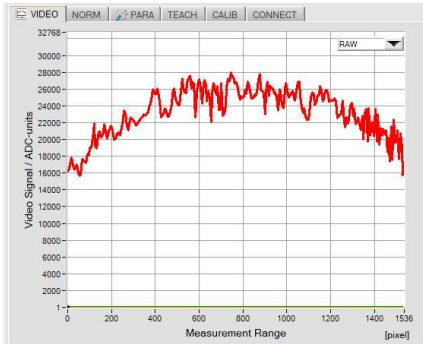

The laser power is adjusted in the VIDEO tab.

The function element for graphic selection must be set to RAW, which means that the raw data of the video signal are sent from the line sensor to the PC.



Please note: The graphic only is refreshed when data transfer is active, which means that data transfer must first be started.

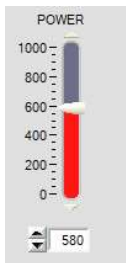

POWER:

By way of adapting the laser power the VIDEO intensity profile should be adjusted in such a way that the curve lies in the upper third of the dynamic range.

Please note:

Changes only become active at the sensor when the SEND button is pressed!

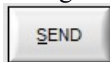

BEFORE WHITE BALANCE:

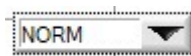
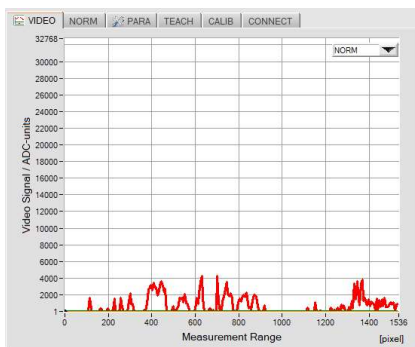

White balancing is performed in the VIDEO tab, the function element for graphic selection must be set to NORM.

White balancing must be performed after every change of parameters, e.g. of the laser POWER, or after a change of the integration time EXPOSE-TIME[ms].

White balancing compensates disturbing extraneous light influences or slight mechanical misalignments between transmitter and receiver.

It is recommended to perform white balancing in regular intervals. In an automated process white balancing can be started with the PLC directly before the measurement. For this purpose a short HIGH pulse (10ms < T < 750ms) is applied through the external input IN1/pin4/yellow.

AFTER WHITE BALANCE:

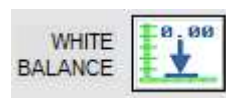
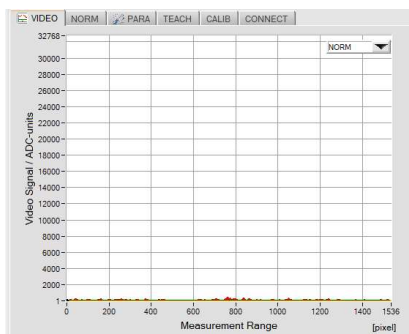

When you click on this software button, white balancing is automatically performed at the control unit. After white balancing the Y-values of the NORM video image should lie close to the X-axis over the complete measurement range of the line sensor.



If the selection field / storage location is set to EEPROM the current white balance information is written to the non-volatile EEPROM of the control unit.

3.2.5 Recording of spray events

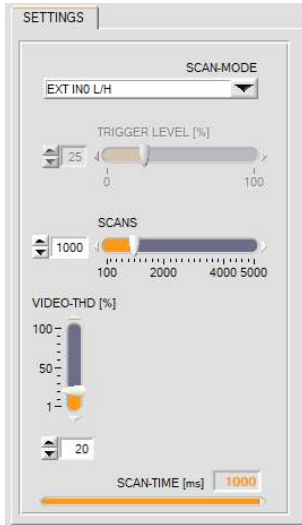

Spray events can be recorded in various ways. A scan-mode must therefore be set first:

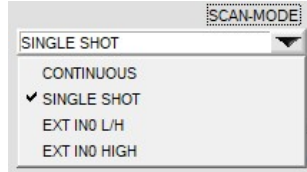

- CONTINUOUS: Continuous spray jet scanning (for test purposes).
- SINGLE SHOT: Single spray jet scan when the START button is pressed.
- EXT IN0 L/H: Spray jet scan triggered with PLC through a L/H edge.
- EXT IN0 HIGH: Spray jet scan triggered with PLC through a HIGH level.

Please note: The graphic only is refreshed when data transfer is active, which means that data transfer must first be started.

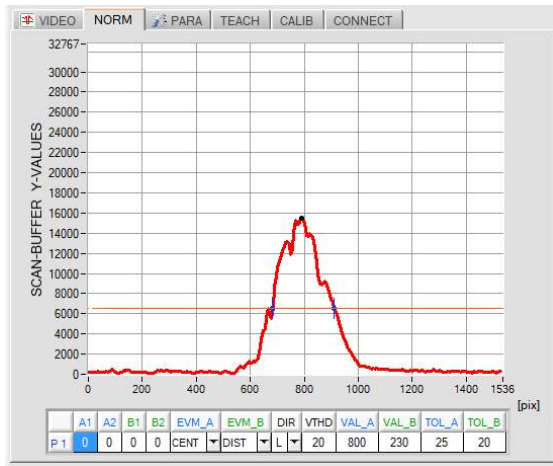

The picture opposite shows a typical picture of a spray recording. Above the X axis (pixels of the line sensor) the spray density distribution is visible as a red curve. Using an adjustable search threshold THD [%] (orange horizontal line), intersection points (edges) can be derived from the density profile. A black cursor indicates the position / height of the density maxima.

In the microcontroller, during the measured value recording, individual images of the line sensor are constantly accumulated and normalized to the spray density distribution after the recording with the SCAN counter reading.

- X-axis: Pixel position (measurement range)
- Y-axis: Normalised "spray density" information



OUTPUT FILE:

With the aid of these function fields, the evaluation results can be stored in an output file



After clicking the File-Open button, a file name can be specified via a dialog box. The storage process can be enabled via the binary switch.

To save to the output file, the [NORM] –TAB must first be selected.



The measurement values are saved in the output file after clicking den [RUN] button (data-request).

Attention:

The data output to the output file is only possible in the following working (trigger) modes:

- SINGLE SHOT,
- EXT-IN0-L/H
- EXT IN0-HIGH

3.2.1 Working with the teach table

	A1	A2	B1	B2	EVM_A	EVM_B	DIR	VTHD	VAL_A	VAL_B	TOL_A	TOL_B
P 0	0	0	0	0	CENT	DIST	L	40	384	384	10	10
P 1	1	-1	1	1	CENT	DIST	L	20	800	230	25	20
P 2	0	0	0	0	CENT	DIST	L	40	575	161	10	10
P 3	0	0	0	0	CEN	DIST	L	40	384	384	10	10
P 4	0	0	0	0	CENT	DIST	L	40	384	384	10	10
P 5	0	0	0	0	CENT	DIST	L	40	384	384	10	10

The learning table can store 16 programs. For each program, two independent edge evaluations EVM_A and EVM_B, as well as one video threshold VTHD and one edge search direction DIR can be specified. Furthermore, for each edge evaluation A and B, a separate tolerance band TOL_A and TOL_B can be preset for the respective teach-in value.

The teach table is used for searching edges in the normalised SCAN data field.

A1:= Edge index position (+1 = first rising edge, evaluation A)

A2:= Edge index position (-1 = first falling edge, evaluation A)

B1:= Edge index position (+1 = first rising edge, evaluation B)

B2:= Edge index position (-1 = first falling edge, evaluation B)

DIR:= Edge search direction L = from left to right (from pixel 1)

EVM_A / EVM_B: = EVALMODE A / B := OFF, POS, CENTER, DISTANCE, DMAX, AREA or SYMMETRY

VTHD:= Video threshold for edge search

VAL_A:= Teach-in value evaluation A

VAL_B:= Teach-in value evaluation B

TOL_A:= Tolerance value evaluation A (+ / - tolerance specification around teach-in value)

TOL_B:= Tolerance value evaluation B (+ / - tolerance specification around teach-in value)

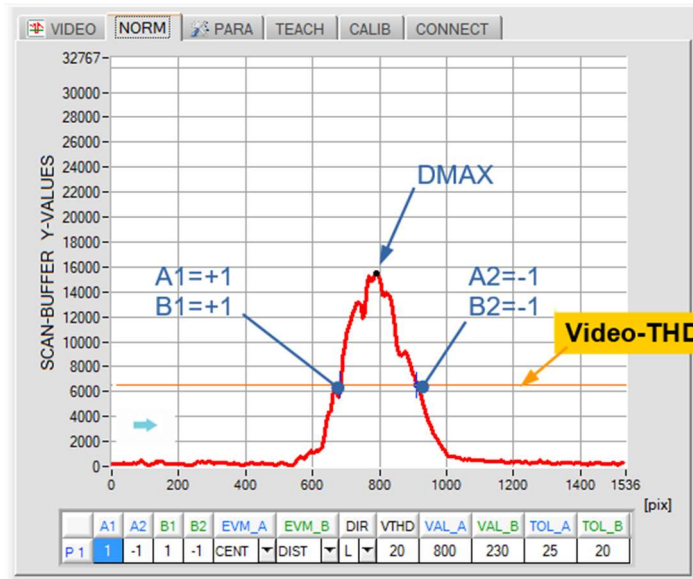

Evaluation A:

Edge search from left to right, DIR=L, VTHD=20% (orange threshold)

EVM_A: CENTER position between the first rising edge [A1=+1] and the first falling edge [A2= -1].

Evaluation B:

Edge search from left to right DIR=L , VTHD=20% (orange threshold)

EVM_B: DISTANCE, distance between first rising edge [B1=+1] to the first falling edge [B2= -1].



These display elements provide information about the detected edges from the normalised data field. The measurement values for the jet positions, based on the known pixel distances of the receiver line, can be calculated with the following formula:

Basic condition: $63.5[\mu\text{m}/\text{pixel}] = \text{Pixel-pitch line sensor}$

$$mm_{value} = (\text{Pixel}_{value} * 63.5)/1000$$

AREA	11271	A	AREA	11271	B	pixel	<input type="checkbox"/>	mm
SYMM	13843	15345	DMAX	SYMM	13843	15345	DMAX	
CENT	51.5	50.2	XMAX	DIST	15.2	50.2	XMAX	

The evaluation quantities AREA, SYMMETRY and DMAX are standardized quantities and refer to the maximum Y value range from 0 to 32767.

DMAX := density-maxima (0 ... 32767)

XMAX := x-position of the density-maxima

AREA := area under curve between edges A1 and A2, or B1 and B2

SYMM:= area ration:

$$SYMM = 16384 * (\text{AREA1})/(\text{AREA1} + \text{AREA2})$$

SYMM [%]:= in percent $SYMM[\%] = 100 * (\text{SYMM})/(32767)$

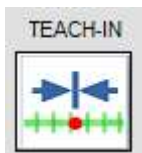

TEACH-IN FUNCTION:

Click the software-button to start the TEACH-IN function on the sensor. For the edge search at position A and position B, the specifications for the edge search (A1, A2, or B1, B2) of the currently activated row of the LEARNING TABLE are used.

The current edge positions and measured values of the respective evaluation modes (AREA, SYMM, DMAX and CENTER) are filled automatically into the LEARNING TABLE. The multifunction LED (orange) on the sensor housing flashes twice.



SET-TTAB-PROG:

Click the software button SET-TTAB-PROG to transfer the selected LEARN VECTOR of the TEACH-TABLE to the sensor. The sensor then works with the values of the selected line (program).

The program to be activated (= line) of the TEACH-TABLE can be selected using the numeric input field. Alternatively, the program can be selected by clicking on the first column in the TEACH-TABLE.

Evaluation of two spray jet positions A and B:

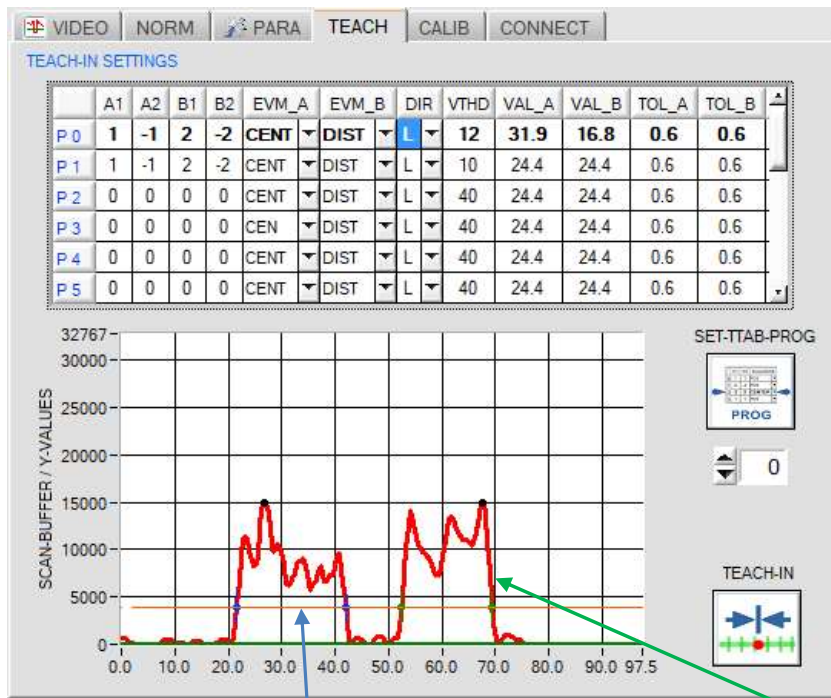

Evaluation A:

Edge search from left to right
DIR = L, VTHD = 12% (orange video image threshold)
EVM_A: CENTER position between the first rising [A1 = + 1] and the first falling edge [A2 = -1].

Evaluation B:

Edge search from left to right
DIR = L, VTHD = 12% (orange video image threshold)
EVM B: DISTANCE, distance between the second rising [B1 = + 2] and the second falling edge [B2 = -2].

AREA 10271 **A**

8 SYMM [%] 2550 17370 DMAX

CENT 31.7 23.0 XMAX

AREA 15442 **B** Pixel

52 SYMM [%] 17073 21827 DMAX

DIST 15.1 61.4 XMAX

A1 [mm] 21.4

A2 [mm] 42.0

B1 [mm] 53.3

B2 [mm] 68.5

Beispiele für Auswerte-Optionen bei Position A und B:

OFF

POS POS 21.5

CENT CENT 31.7

DIST DIST 15.1

DMAX 17370 DMAX

AREA AREA 10271

SYMM 52 SYMM [%] 17073

Evaluation of position A or B is deactivated. The corresponding fields in the LEARNING TABLE are "greyed out".

Evaluation of an edge position. e.g. POS A1 = +1 first rising edge. Edges result from the intersection of video threshold / density curve.

Evaluation of the center position POSITION A between the first rising (A1 = +1) and the first falling edge (A2 = -1).

Evaluation of the distance at POSITION B between the second rising edge (B1 = +2) and the second falling edge (B2 = -2).

Evaluation of density maxima at POSITION A between the two edges (A1 = +1, A2 = -1)

Evaluation of the area under the density curve at POSITION A between the two edges (A1 = +1, A2 = -1).

Evaluation of the symmetry at POSITION B between the second rising edge (B2 = +2) and the second falling edge (B2 = -2).

3.3 Procedure for measuring with the PLC

To integrate the measurement process into the PLC program process, one of the two “triggered” operating modes (SCAN MODE) EXT IN0 HIGH or EXT IN0 L/H can be set. The associated input and output signals must be connected to the 8-pin PLC socket (see Chapter 3.2.2).



The spray jet check process is divided into the following steps:

1. START WHITE BALANCE
2. CHECK WHITE BALANCE
3. START SPRAYING
4. START/TRIGGER MEASUREMENT
5. CHECK SPRAYING PROCESS
6. STOP SPRAYING

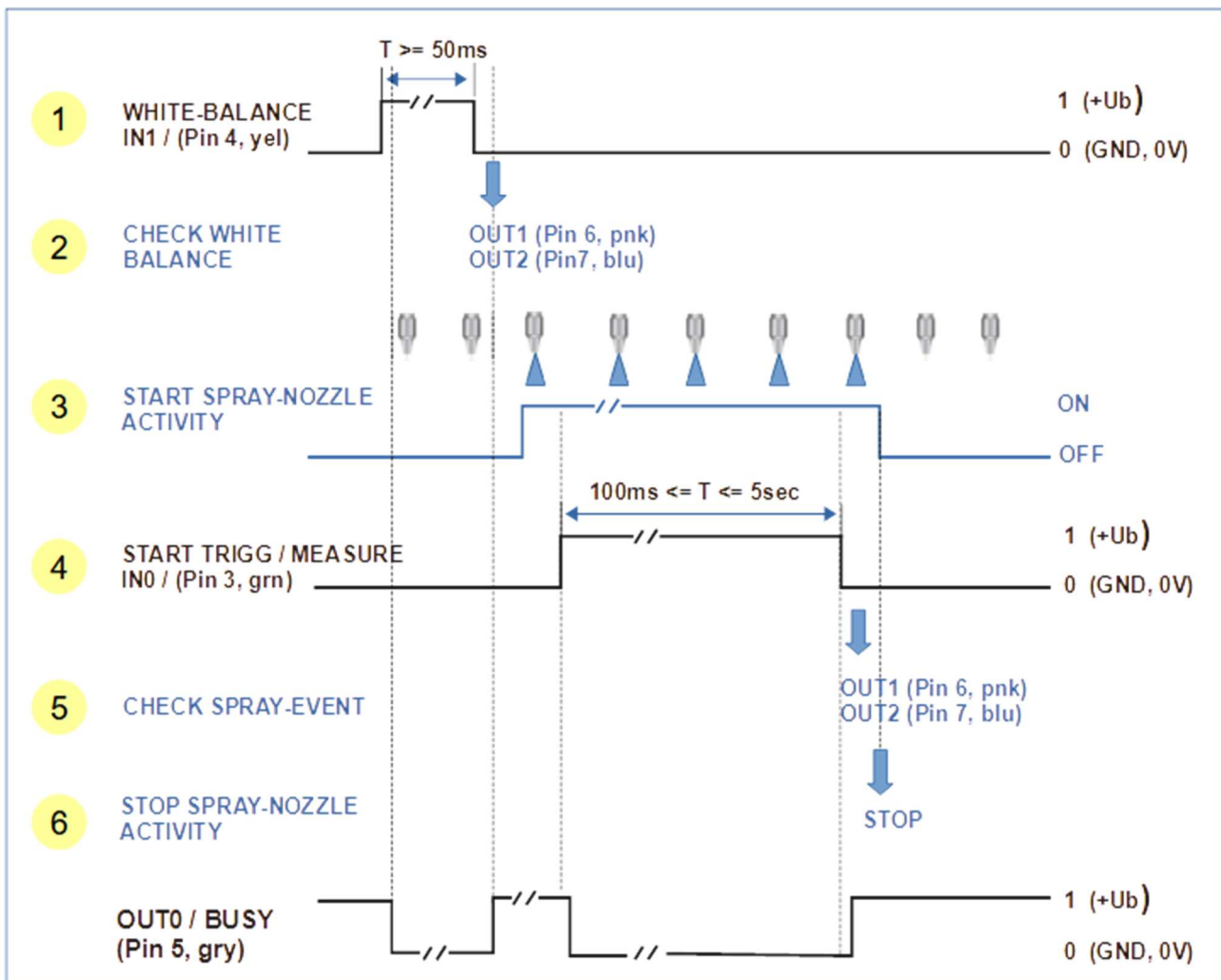

3.3.1 WHITE BALANCE

The WHITE BALANCE should be carried out shortly before the spray event. The procedure is triggered via a digital pulse of at least 50ms duration at IN1/Pin4/yellow. With the rising edge of IN1, the current VIDEO image on the line sensor is checked according to two criteria.

- A) Checking the level of the mean value of the RAW signal (dirt accumulation/intensity curve) >> OUT1.
- B) Checking the video image for the presence of edges (e.g. deposits of drops) >> OUT2.

The results of both tests are available at the corresponding digital outputs (OUT1, OUT2) after the rising edge of the BUSY signal for the PLC to read out.

<div style="border: 1px solid #ccc; padding: 5px; margin-bottom: 10px;"> <p style="text-align: center; margin: 0;">SCAN-MODE</p> <p style="margin: 0;">EXT IN0 L/H ▼</p> </div> <div style="display: flex; align-items: center; margin-bottom: 10px;"> <div style="display: flex; flex-direction: column; gap: 5px;"> <div style="display: flex; justify-content: space-around; width: 100%;"> <div style="text-align: center;">● IN0</div> <div style="text-align: center;">● OUT0</div> </div> <div style="display: flex; justify-content: space-around; width: 100%;"> <div style="text-align: center;">● IN1</div> <div style="text-align: center;">● OUT1</div> </div> <div style="display: flex; justify-content: space-around; width: 100%;"> <div style="text-align: center;">● OUT2</div> </div> </div> <div style="margin-left: 10px;"> <p>SPS: IN1 = HIGH, OUT0/BUSY = HIGH</p> </div> </div> <div style="display: flex; align-items: center; margin-bottom: 10px;"> <div style="display: flex; flex-direction: column; gap: 5px;"> <div style="display: flex; justify-content: space-around; width: 100%;"> <div style="text-align: center;">● IN0</div> <div style="text-align: center;">● OUT0</div> </div> <div style="display: flex; justify-content: space-around; width: 100%;"> <div style="text-align: center;">● IN1</div> <div style="text-align: center;">● OUT1</div> </div> <div style="display: flex; justify-content: space-around; width: 100%;"> <div style="text-align: center;">● OUT2</div> </div> </div> </div> <div style="display: flex; align-items: center; margin-bottom: 10px;"> <div style="display: flex; flex-direction: column; gap: 5px;"> <div style="display: flex; justify-content: space-around; width: 100%;"> <div style="text-align: center;">● IN0</div> <div style="text-align: center;">● OUT0</div> </div> <div style="display: flex; justify-content: space-around; width: 100%;"> <div style="text-align: center;">● IN1</div> <div style="text-align: center;">● OUT1</div> </div> <div style="display: flex; justify-content: space-around; width: 100%;"> <div style="text-align: center;">● OUT2</div> </div> </div> </div> <div style="display: flex; align-items: center; margin-bottom: 10px;"> <div style="display: flex; flex-direction: column; gap: 5px;"> <div style="display: flex; justify-content: space-around; width: 100%;"> <div style="text-align: center;">● IN0</div> <div style="text-align: center;">● OUT0</div> </div> <div style="display: flex; justify-content: space-around; width: 100%;"> <div style="text-align: center;">● IN1</div> <div style="text-align: center;">● OUT1</div> </div> <div style="display: flex; justify-content: space-around; width: 100%;"> <div style="text-align: center;">● OUT2</div> </div> </div> </div>

3.3.2 START / TRIGGER MEASUREMENT

To optimize the evaluation, the spraying process should be triggered before the triggering (start of the measurement) (e.g. 100ms). Furthermore, the spraying process should be slightly delayed beyond the end of the triggering (e.g. 100ms). This procedure prevents discontinuities when switching the spray nozzle on/off from being included in the evaluation.

The trigger process on the control electronics takes place via a HIGH level at the digital input IN0/Pin3/green. Data recording starts with the L/H edge at IN0. The data recording stops with the subsequent H/L level change. The evaluation result is available after typically 1 ms and can be read out via the RS-232 interface (command <ORDER=8>). A maximum of 5000 scans can be carried out, at a scan rate of 1kHz this corresponds to a period of 5 seconds.

The evaluation results for the edge evaluation at positions POS-A and POS-B are each output at a digital output.

<div style="border: 1px solid #ccc; padding: 5px; margin-bottom: 10px;"> <p style="text-align: center; margin: 0;">SCAN-MODE</p> <p style="margin: 0;">EXT IN0 L/H ▼</p> </div> <div style="display: flex; align-items: center; margin-bottom: 10px;"> <div style="display: flex; flex-direction: column; gap: 5px;"> <div style="display: flex; justify-content: space-around; width: 100%;"> <div style="text-align: center;">● IN0</div> <div style="text-align: center;">● OUT0</div> </div> <div style="display: flex; justify-content: space-around; width: 100%;"> <div style="text-align: center;">● IN1</div> <div style="text-align: center;">● OUT1</div> </div> <div style="display: flex; justify-content: space-around; width: 100%;"> <div style="text-align: center;">● OUT2</div> </div> </div> <div style="margin-left: 20px;"> <p>SPS: IN0 = HIGH, OUT0/BUSY = HIGH</p> </div> </div> <div style="display: flex; flex-direction: column; gap: 10px;"> <div style="border: 1px solid #ccc; padding: 5px; width: 100%;"> <div style="display: flex; justify-content: space-around; width: 100%;"> <div style="text-align: center;">● IN0</div> <div style="text-align: center;">● OUT0</div> </div> <div style="display: flex; justify-content: space-around; width: 100%;"> <div style="text-align: center;">● IN1</div> <div style="text-align: center;">● OUT1</div> </div> <div style="display: flex; justify-content: space-around; width: 100%;"> <div style="text-align: center;">● OUT2</div> </div> </div> <div style="border: 1px solid #ccc; padding: 5px; width: 100%;"> <div style="display: flex; justify-content: space-around; width: 100%;"> <div style="text-align: center;">● IN0</div> <div style="text-align: center;">● OUT0</div> </div> <div style="display: flex; justify-content: space-around; width: 100%;"> <div style="text-align: center;">● IN1</div> <div style="text-align: center;">● OUT1</div> </div> <div style="display: flex; justify-content: space-around; width: 100%;"> <div style="text-align: center;">● OUT2</div> </div> </div> <div style="border: 1px solid #ccc; padding: 5px; width: 100%;"> <div style="display: flex; justify-content: space-around; width: 100%;"> <div style="text-align: center;">● IN0</div> <div style="text-align: center;">● OUT0</div> </div> <div style="display: flex; justify-content: space-around; width: 100%;"> <div style="text-align: center;">● IN1</div> <div style="text-align: center;">● OUT1</div> </div> <div style="display: flex; justify-content: space-around; width: 100%;"> <div style="text-align: center;">● OUT2</div> </div> </div> <div style="border: 1px solid #ccc; padding: 5px; width: 100%;"> <div style="display: flex; justify-content: space-around; width: 100%;"> <div style="text-align: center;">● IN0</div> <div style="text-align: center;">● OUT0</div> </div> <div style="display: flex; justify-content: space-around; width: 100%;"> <div style="text-align: center;">● IN1</div> <div style="text-align: center;">● OUT1</div> </div> <div style="display: flex; justify-content: space-around; width: 100%;"> <div style="text-align: center;">● OUT2</div> </div> </div> </div>
--

3.4 Carrying out the measurement system analysis (MSA)

The functional elements for the measuring system analysis [MSA] are located under the CALIB tab:



The measuring system analysis (MSA) serves to prove the functionality of the L-LAS-TB-SC spray control system. The verification takes place in three steps. The first two steps (1) and (2) take place with a clear field of view on the sensor! Before step (3), a calibration attachment is mounted on the receiver unit of the spray control system. The calibration attachment consists of optical filters that generate a "damping distribution" over the measuring range of the sensor. With the help of the calibration attachment, a defined "spray event" can be simulated and subjected to a further evaluation.

Calibration Tool for the measurement system analysis (MSA):

The calibration attachment *ABL-L-LAS-TB-100-CAL-NG11* consists of a plastic holder with an optical filter. The calibration attachment generates a fixed "damping distribution" over the measuring range of the sensor. With its help, a defined "spraying event" can be simulated and subjected to further evaluation. For this purpose, an optical damping filter (NG11) is attached to a part of the attachment. The calibration attachment can be attached to the receiver housing using four M3 Allen screws when performing the MSA.



Abb.: 1 Calibration Attachment Tool ABL-L-LAS-TB100-CAL-NG11



Abb.: 2 Calibration Attachment Tool ABL-L-LAS-TB100-CAL-NG11

3.3.1 Step1: Checking the intensity curve (RAW)

Before performing the actual MSA, the intensity curve (RAW) of the video-image over the active area (pixel) of the line sensor must first be checked. The intensity curve of the line sensor must be in the range of 30% to 90% of the dynamic range.

After clicking the [Yes] button, the current intensity profile is transferred to the PC. The permitted intensity band is highlighted in green. The red intensity curve of the RAW signal should be in this area.

SETTINGS-BUTTON



If the intensity curve (red curve) is not within the permitted intensity range, the intensity range can be adjusted if necessary. For this purpose, after clicking on the SETTINGS button, the corresponding function fields are activated.

3.3.2 Step2: Checking the WHITE-BALANCING

After clicking the [Yes] button, the white light calibration is carried out on the sensor. The current SCAN data curve (red) is transferred from the sensor to the PC. The permitted band for white light adjustment is highlighted in green. The red SCAN data curve should lie in this area.

3.3.3 Step3: Start of the MSA

The "spray simulation" takes place after attaching a special calibration attachment in front of the receiver unit of the spray control system. The calibration attachment is used to simulate a defined "spray density distribution".

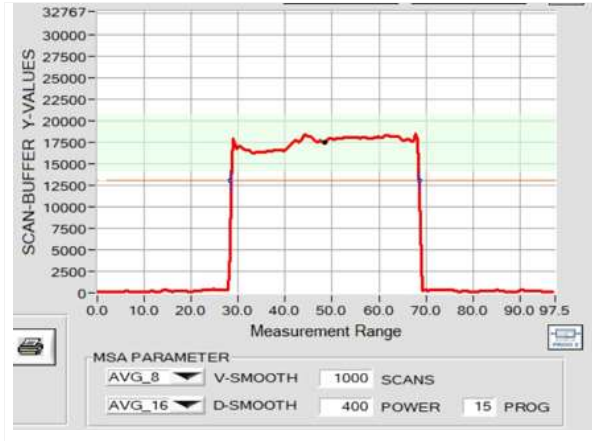

SENSOR COVERED

(3) START MSA

20000 SETPOINT

10 +/- TOL [%]

After clicking the (3) START MSA button, a single shot test measurement is triggered on the sensors with the following factory settings:

- SCAN-MODE = SINGLE SHOT
- 1000 SCANS
- EVAL-PROG = 15 (A = CENTER, B = DIST)
- POWER = 1000

MSA PARAMETER

AVG_8 V-SMOOTH 1000 SCANS

AVG_32 D-SMOOTH 400 POWER 15 PROG

When performing the single measurement (SINGLE-SHOT) for the MSA, the PROG = 15 evaluation program in the learning table is used with the parameters shown here.

AREA	17465	A	AREA	17465	B	Pixel	mm
SYMM [%]	16383	17465	SYMM [%]	16382	17465	DMAX	
CENT	48.5	48.5	DIST	40.3	48.5	XMAX	

The "spray density - intensity profile" detected during the MSA measurement is automatically evaluated and transferred to the PC.

The mean value of the density curve (DMAX) and the width (DIST) as well as the center position (CENTER) of the "spray distribution" are evaluated.

SETTINGS-TASTE:



If the mean value (black cursor) resulting from the density profile (red curve) is not within the permitted tolerance range, the SETPOINT value and/or the TOLERANCE value can be adjusted if necessary. For this purpose, after clicking on the SETTINGS button, the corresponding function fields are activated..

4 Annex

4.1 Display elements

At the housing of the *L-LAS-TB-...-AL-SC control unit* there are 4 two-color LEDs that visualise system states.

L-LAS-TB- ... - R-AL-SC (control unit / receiver)

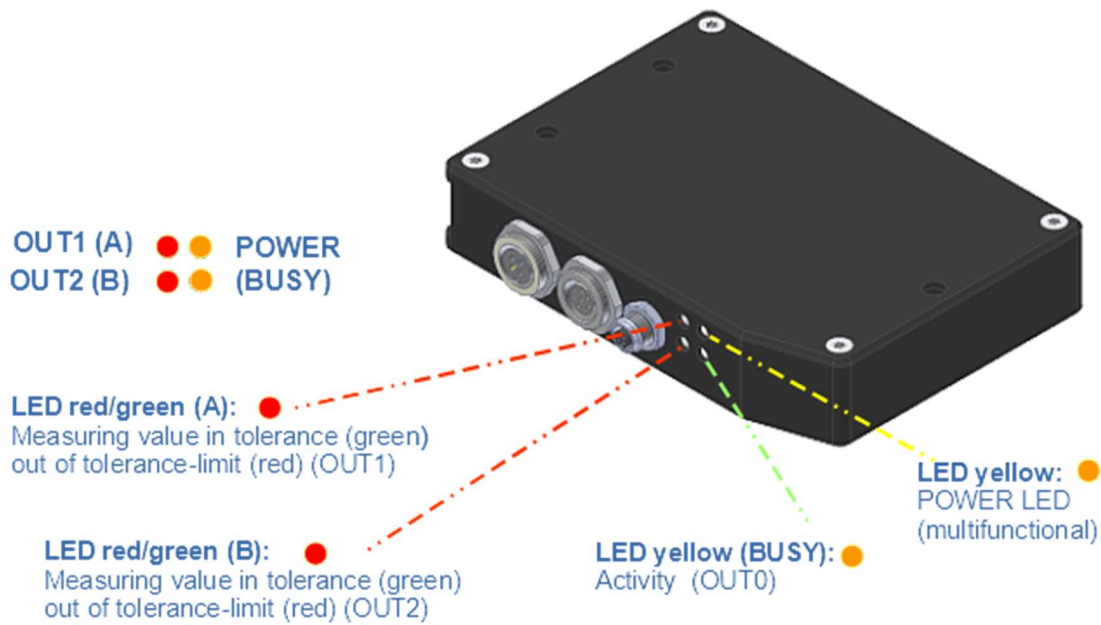

4.2 Function of digital input IN0, IN1

4.2.1 PLC connection: WHITE-BALANCE procedure

The white balance procedure should be carried out shortly before the spray event. The adjustment is triggered via a digital pulse of at least 50ms duration at IN1/Pin4/yellow. The current VIDEO image on the line sensor is checked with the rising edge of IN1. On the one hand, the height of the mean value of the RAW signal (intensity curve) is checked, on the other hand, the video image is checked for the presence of edges (dirt, e.g. from drops). The results of both tests are available at the corresponding digital output (OUT1, OUT2) after the rising edge of the BUSY signal for the PLC to read out.

Digital output OUT0/pin5/grey (BUSY):

The digital output OUT0 is used for the "handshake" with the PLC. As soon as the white balance is started on the sensor, this is indicated by a level change at the digital output OUT0/Pin5/grey.

The evaluation result is available as soon as the BUSY output on the sensor changes back to its output level.

The PLC timing for the INVERS output polarity is shown below.

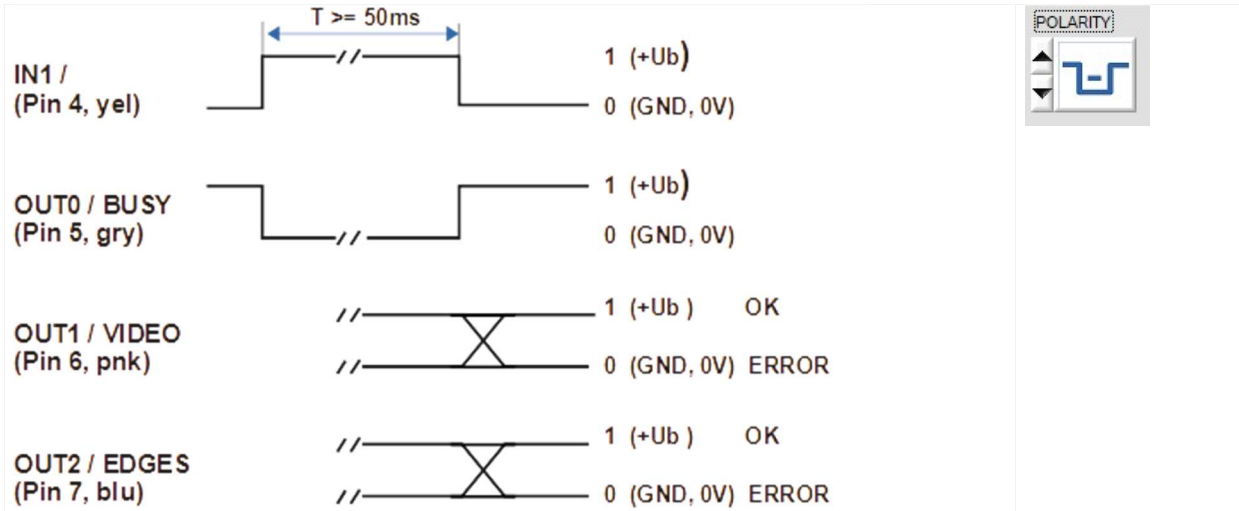

4.2.2 PLC connection: Trigger Spray-Event

Measurement value recording in the control unit can be started simultaneously with the spray process. Triggering at the control unit is performed with a HIGH level at digital input IN0/pin3/green. Data recording starts with a L/H edge at IN0, and stops with the following H/L level change. The evaluation result is available after t_{yp} . 1ms and can be read out through the RS-232 interface (order <ORDER=8>). A maximum of 5000 scans can be performed, which with a scan rate of 1kHz means a time of 5 seconds.



The "triggered" operating mode (SCAN-MODE) must first be set with the *L-LAS-TB-Spray-Control-Scope* software.

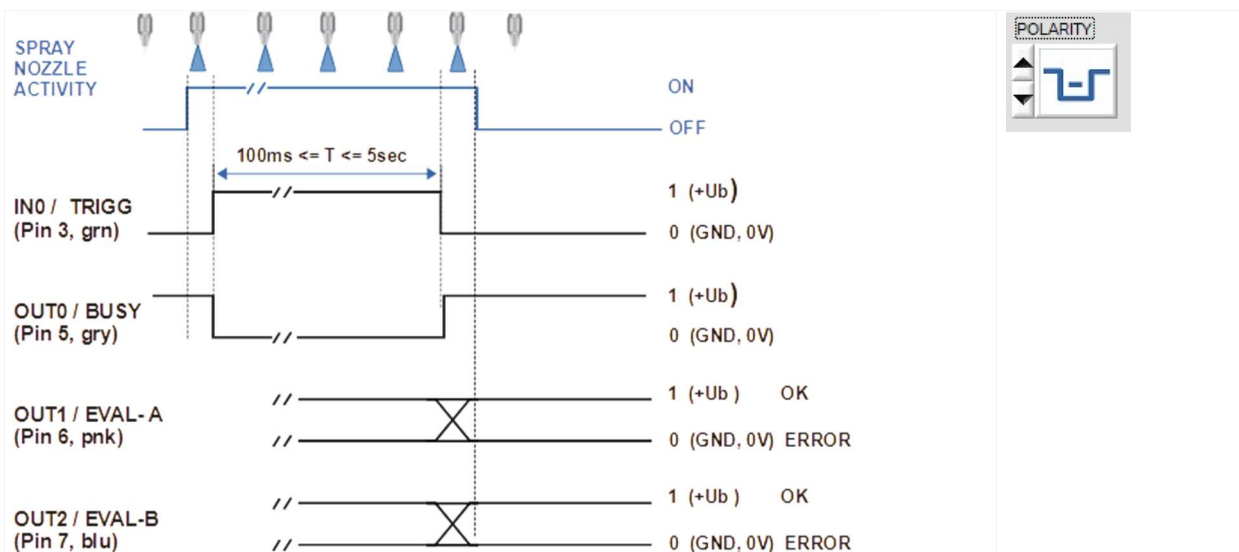

The PLC timing for the INVERS output polarity is shown below.



4.3 Laser warning

LASER WARNING	
<p>Solid state laser, $\lambda=670$ nm, 0.4mW max. optical power, Laser class 1 acc. to EN 60825-1 The use of these laser transmitters therefore requires no additional protective measures.</p>	
	

4.4 RS232 interface protocol

RS-232 data transmission:

- Standard RS232 serial interface, no hardware handshake, 3-wire-connection: GND, TXD, RXD
- Speed: 9600 baud, 19200 baud, 38400 baud, 57600 baud or 115200 baud
- 8 data bits, NO parity bit, 1 STOP bit, binary mode
- Default baud rate: 115200 baud

METHOD:

The sensor control unit always behaves passively. Data exchange therefore is initiated by the PC (or PLC). The PC sends a data package ("frame") either with or without appended data, to which the sensor control unit responds with a frame that matches the request. The data package comprises a **HEADER** and the optional **DATA**.

HEADER

- 1. Byte** : Synchronisation byte <SYNC> (85dez = 0x55hex)
- 2. Byte** : Order byte <ORDER>
- 3. Byte** : Argument <ARG LO>
- 4. Byte** : Argument <ARG HI>
- 5. Byte** : Data length <LEN LO>
- 6. Byte** : Data length <LEN HI>
- 7. Byte** : Checksum Header <CRC8 HEAD>
- 8. Byte** : Checksum Data <CRC8 DATA>

The first byte is a synchronisation byte and always is 85_{dez} (55_{hex}).

The second byte is the so-called order byte <ORDER>, it determines the action that should be performed (send data, save data, etc.).

A 16-bit value <ARG> follows as the third and fourth byte. Depending on the order the argument is assigned a corresponding value.

The fifth and sixth byte again form a 16-bit value <LEN>. This value states the number of appended data bytes. Without appended data <LEN=0>, the maximum data length is 512 bytes <LEN=512>. The seventh byte is formed with the CRC8 checksum over all data bytes.

The eighth byte is the CRC8 checksum for the header and is formed from bytes 0 up to and incl. 7. The header always has a total length of 8 bytes. The complete frame may contain between 8 and 520 bytes.

Byte1 Header	Byte2 Header	Byte3 Header	Byte4 Header	Byte5 Header	Byte6 Header	Byte7 Header	Byte8 Header	Byte9 Data	Byte10 Data	...	Byte n+7 Data	Byte n+8 Data
0x55	<ORDER>	<ARG> (lo byte)	<ARG> (hi byte)	<LEN> (lo byte)	<LEN> (hi byte)	CRC8 (Data)	CRC8 (Header)	Data1 (lo byte)	Data1 (hi byte)	...	Data n/2 (lo byte)	Data n/2 (hi byte)

<ORDER>	Meaning of the 2nd byte <order>:	ORDER-TABLE
0	NOP	no operation
1	Send parameter from PC to L-LAS-RAM	PC ⇒ L-LAS-RAM
2	Get parameter from L-LAS-RAM	L-LAS-RAM ⇒ PC
3	Send parameter from PC to L-LAS EEPROM	PC ⇒ L-LAS-EEPROM
4	Get parameter from L-LAS EEPROM	L-LAS-EEPROM ⇒ PC
5	Echo check: Get echo from L-LAS	first word=0x00AA=170dec
7	Get firmware version info from L-LAS	L-LAS ⇒ PC
8	Get measured values from L-LAS	L-LAS-RAM ⇒ PC
9	Get video image from L-LAS	L-LAS-RAM ⇒ PC
11	Activate single measurement data scan (SINGLE SHOT)	PC ⇒ L-LAS-RAM
12	Activate white balance (WHITE-BALANCE)	L-LAS-RAM ⇒ PC
16	Activate evaluation program (PROG-NO)	PC ⇒ L-LAS-RAM
26	Send teach vector (TEACH-TABLE VECTOR)	PC ⇒ L-LAS-RAM
27	Get teach vector (TEACH-TABLE VECTOR)	L-LAS-RAM ⇒ PC
30	Activate MSA procedure at L-LAS	PC ⇒ L-LAS-RAM

CRC8 checksum

The so-called "Cyclic Redundancy Check" or CRC is used to verify data integrity. This algorithm makes it possible to detect individual bit errors, missing bytes, and faulty frames. For this purpose a value - the so-called checksum - is calculated over the data (bytes) to be checked and is transmitted together with the data package. Calculation is performed according to an exactly specified method based on a generator polynomial. The length of the checksum is 8 bit (= 1 byte). The generator polynomial is: $X^8+X^5+X^4+1$

To verify the data after they have been received, CRC calculation is performed once again. If the sent and the newly calculated CRC values are identical, the data are without error. The following pseudo code can be used for checksum calculation:

```
calcCRC8 (data[ ], table[ ])
Input:   data[ ], n data of unsigned 8bit
           table[ ], 256 table entries of unsigned 8bit
Output: crc8, unsigned 8bit

crc8 := AAhex

for i := 1 to n do
    idx := crc8 EXOR data[ i ]
    crc8 := table[ idx ]
endfor

return   crc8
```

table[]

0	94	188	226	97	63	221	131	194	156	126	32	163	253	31	65
157	195	33	127	252	162	64	30	95	1	227	189	62	96	130	220
35	125	159	193	66	28	254	160	225	191	93	3	128	222	60	98
190	224	2	92	223	129	99	61	124	34	192	158	29	67	161	255
70	24	250	164	39	121	155	197	132	218	56	102	229	187	89	7
219	133	103	57	186	228	6	88	25	71	165	251	120	38	196	154
101	59	217	135	4	90	184	230	167	249	27	69	198	152	122	36
248	166	68	26	153	199	37	123	58	100	134	216	91	5	231	185
140	210	48	110	237	179	81	15	78	16	242	172	47	113	147	205
17	79	173	243	112	46	204	146	211	141	111	49	178	236	14	80
175	241	19	77	206	144	114	44	109	51	209	143	12	82	176	238
50	108	142	208	83	13	239	177	240	174	76	18	145	207	45	115
202	148	118	40	171	245	23	73	8	86	180	234	105	55	213	139
87	9	235	181	54	104	138	212	149	203	41	119	244	170	72	22
233	183	85	11	136	214	52	106	43	117	151	201	74	20	246	168
116	42	200	150	21	75	169	247	182	232	10	84	215	137	107	53

4.4.1 ORDER=5: ECHO-CHECK, READ LINE OK of sensor

< ORDER = 5 >

DATA FRAME PC → Sensor (8 bytes)

Byte1 Header	Byte2 Header	Byte3 Header	Byte4 Header	Byte5 Header	Byte6 Header	Byte7 Header	Byte8 Header
0x55	<order>	<ARG> (lo byte)	<ARG> (hi byte)	<LEN> (lo byte)	<LEN> (hi byte)	CRC8 (Data)	CRC8 (Header)
85	5	0	0	0	0	170	60
ARG=0			LEN=0				

DATA FRAME Sensor → PC (8 bytes)

Byte1 Header	Byte2 Header	Byte3 Header	Byte4 Header	Byte5 Header	Byte6 Header	Byte7 Header	Byte8 Header
0x55	<order>	<ARG> (lo byte)	<ARG> (hi byte)	<LEN> (lo byte)	<LEN> (hi byte)	CRC8 (Data)	CRC8 (Header)
85	5	170	0	0	0	170	178
ARG=170			LEN=0				

Serial – number of sensor = <ARG> value

4.4.2 ORDER=7: Lese FIRMWARE-VERSIONS-STRING von Sensor

< ORDER = 7 >

DATA FRAME PC → Sensor (8 bytes)

Byte1 Header	Byte2 Header	Byte3 Header	Byte4 Header	Byte5 Header	Byte6 Header	Byte7 Header	Byte8 Header
0x55	<order>	<ARG> (lo byte)	<ARG> (hi byte)	<LEN> (lo byte)	<LEN> (hi byte)	CRC8 (Data)	CRC8 (Header)
85 (dec)	7	0	0	0	0	170	82
ARG=0			LEN=0				

DATA FRAME Sensor → PC (8 + 72) bytes

Byte1 Header	Byte2 Header	Byte3 Header	Byte4 Header	Byte5 Header	Byte6 Header	Byte7 Header	Byte8 Header	Byte9 Data	Byte10 Data	Byte11 Data	Byte12 Data
0x55	<order>	<ARG> (lo byte)	<ARG> (hi byte)	<LEN> (lo byte)	<LEN> (hi byte)	CRC8 (Data)	CRC8 (Header)	ASCII	ASCII	ASCII	ASCII
85 (dec)	7	170	0	72	0	XXX	82	L	-	L	A
ARG=170 (Ser.-No)			LEN=72								

Byte13 Data	Byte14 Data	Byte15 Data	Byte16 Data	Byte17 Data	Byte18 Data	Byte19 Data	Byte20 Data	Byte21 Data	Byte22 Data	Byte23 Data	Byte24 Data
ASCII	ASCII	ASCII	ASCII	ASCII	ASCII	ASCII	ASCII	ASCII	ASCII	ASCII	ASCII
S	-	T	B	-	S	C	-	T	S	L	X

Byte25 Data	Byte26 Data	Byte27 Data	Byte28 Data	Byte29 Data	Byte30 Data	Byte31 Data	Byte32 Data	Byte33 Data	Byte34 Data	Byte35 Data	Byte36 Data
ASCII	ASCII	ASCII	ASCII	ASCII	ASCII	ASCII	ASCII	ASCII	ASCII	ASCII	ASCII
X	-	A	L		V	1	.	0	.	0	

Byte37 Data	Byte38 Data	Byte39 Data	Byte40 Data	Byte41 Data	Byte42 Data	Byte43 Data	Byte44 Data	Byte45 Data	Byte46 Data	Byte47 Data	Byte48 Data
ASCII	ASCII	ASCII	ASCII	ASCII	ASCII	ASCII	ASCII	ASCII	ASCII	ASCII	ASCII
	2	6	/	M	A	R	/	1	8		

Byte49 Data	Byte50 Data	Byte51 Data	Byte52 Data	Byte53 Data	Byte54 Data	Byte55 Data	Byte56 Data	Byte57 Data	Byte58 Data	Byte59 Data	Byte60 Data
ASCII	ASCII	ASCII	ASCII	ASCII	ASCII	ASCII	ASCII	ASCII	ASCII	ASCII	ASCII

Byte61 Data	Byte62 Data	Byte63 Data	Byte64 Data	Byte65 Data	Byte66 Data	Byte67 Data	Byte68 Data	Byte69 Data	Byte70 Data	Byte71 Data	Byte72 Data
ASCII	ASCII	ASCII	ASCII	ASCII	ASCII	ASCII	ASCII	ASCII	ASCII	ASCII	ASCII

Byte73 Data	Byte74 Data	Byte75 Data	Byte76 Data	Byte77 Data	Byte78 Data	Byte79 Data	Byte80 Data
ASCII	ASCII	ASCII	ASCII	ASCII	ASCII	ASCII	ASCII

4.4.3 ORDER=8: Get MEASURED-VALUES from L-LAS sensor

< ORDER = 8 >

DATA FRAME PC → Sensor (8 bytes)

Byte1 Header	Byte2 Header	Byte3 Header	Byte4 Header	Byte5 Header	Byte6 Header	Byte7 Header	Byte8 Header
0x55	<order>	<ARG> (lo byte)	<ARG> (hi byte)	<LEN> (lo byte)	<LEN> (hi byte)	CRC8 (Data)	CRC8 (Header)
85 (dec)	8	0	0	0	0	170	118
		ARG=0		LEN=0			

DATA FRAME Sensor → PC (8 + 64) bytes

Byte1 Header	Byte2 Header	Byte3 Header	Byte4 Header	Byte5 Header	Byte6 Header	Byte7 Header	Byte8 Header	Byte9 Data	Byte10 Data	Byte11 Data	Byte12 Data
0x55	<order>	<ARG> (lo byte)	<ARG> (hi byte)	<LEN> (lo byte)	<LEN> (hi byte)	CRC8 (Data)	CRC8 (Header)	Raw1 (lo byte)	Raw1 (hi byte)	Raw2 (lo byte)	Raw2 (hi byte)
85 (dec)	8	0	0	64	0	xxx	118	180	2	163	3
		ARG=0		LEN=64				PIX_A1 = 692		PIX_A2 = 931	

Byte13 Data	Byte14 Data	Byte15 Data	Byte16 Data	Byte17 Data	Byte18 Data	Byte19 Data	Byte20 Data	Byte21 Data	Byte22 Data	Byte23 Data	Byte24 Data
Raw3	Raw3	Raw4	Raw4	Raw5	Raw5	Raw6	Raw6	Raw7	Raw7	Raw8	Raw8
180	2	163	3	43	3	239	0	241	59	241	59
PIX_B1 = 692		PIX_B2 = 931		XVAL_A = 811		XVAL_B = 239		DMAX_A = 15345		DMAX_B = 15345	

Byte25 Data	Byte26 Data	Byte27 Data	Byte28 Data	Byte29 Data	Byte30 Data	Byte31 Data	Byte32 Data	Byte33 Data	Byte34 Data	Byte35 Data	Byte36 Data
Raw9	Raw9	Raw10	Raw10	Raw11	Raw11	Raw12	Raw12	Raw13	Raw13	Raw14	Raw14
22	3	22	3	7	44	7	44	19	54	19	54
IDX_A = 790		IDX_B = 790		AREA_A = 11271		AREA_B = 11271		SYMM_A = 13843		SYMM_B = 13843	

Byte61 Data	Byte62 Data	Byte63 Data	Byte64 Data	Byte65 Data	Byte66 Data	Byte67 Data	Byte68 Data	Byte69 Data	Byte70 Data	Byte71 Data	Byte72 Data
Raw27	Raw27	Raw28	Raw28	Raw29	Raw29	Raw30	Raw30	Raw31	Raw31	Raw32	Raw32
231	3	232	3	231	3	0	0	0	0	0	0
DYNTIME=999		SCANCOUNT=1000		SCANTIME=999				RAW_31=0		RAW_32=0	

Name	Value	Type
raw	0x0073263C	raw_struct
raw.pixA1	692	unsigned short
raw.pixA2	931	unsigned short
raw.pixB1	692	unsigned short
raw.pixB2	931	unsigned short
raw.xvalA	811	unsigned short
raw.xvalB	239	unsigned short
raw.dmaxA	15345	unsigned short
raw.dmaxB	15345	unsigned short
raw.imaxA	790	unsigned short
raw.imaxB	790	unsigned short
raw.areaA	11271	unsigned short
raw.areaB	11271	unsigned short
raw.symmA	13843	unsigned short
raw.symmB	13843	unsigned short
raw.emodA	2	unsigned short
raw.emodB	3	unsigned short
raw.edcjet	2	unsigned short
raw.raw16	0	unsigned short
raw.eprog	1	unsigned short
raw.instate	0	unsigned short
raw.outstate	0	unsigned short
raw.runstate	1	short
raw.videomax	31964	unsigned short
raw.mvstart	0	unsigned short
raw.mvend	0	unsigned short
raw.dynpow	0	unsigned short
raw.dyntime	999	unsigned short
raw.scncnt	1000	unsigned short
raw.scrntime	999	long int
raw.raw31	0	unsigned short
raw.raw32	0	unsigned short

4.4.4 ORDER=9: Get DATA BUFFER from L-LAS sensor

< ORDER = 9 >

ATTENTION: A maximum of 256 integer values = 512 bytes of data can be read out.

The argument <ARG> of the header frame determines which data memory is read out:

- ARG = 0 : STATISTICS DATA BUFFER AFTER EVALUATION (NORM value)
- ARG = 1 : RAW DATA CMOS VIDEO LINE (256 pixels distributed over full pixel number)
- ARG = 2 : WHITE BALANCE BUFFER (256 values distributed over full pixel number)
- ARG = 3 : CURRENT SCAN BUFFER (NORM value)

DATA FRAME PC → Sensor

Byte1 Header	Byte2 Header	Byte3 Header	Byte4 Header	Byte5 Header	Byte6 Header	Byte7 Header	Byte8 Header
0x55	<order>	<ARG> (lo byte)	<ARG> (hi byte)	<LEN> (lo byte)	<LEN> (hi byte)	CRC8 (Data)	CRC8 (Header)
85 (dec)	9	0	0	0	0	170	185
ARG=0				LEN=0			

DATA FRAME Sensor → PC

Byte1 Header	Byte2 Header	Byte3 Header	Byte4 Header	Byte5 Header	Byte6 Header	Byte7 Header	Byte8 Header	Byte9 Data	Byte10 Data	Byte11 Data	Byte12 Data
0x55	<order>	<ARG> (lo byte)	<ARG> (hi byte)	<LEN> (lo byte)	<LEN> (hi byte)	CRC8 (Data)	CRC8 (Header)	Para1 (lo byte)	Para1 (hi byte)	Para2 (lo byte)	Para2 (hi byte)
85 (dec)	9	0	0	0	1	XXX	185	200	0	220	0
ARG=0				LEN=256				PIX1=200		PIX2=220	

Byte13 Data	Byte14 Data	Byte15 Data	Byte16 Data	Byte17 Data	Byte18 Data	Byte19 Data	Byte20 Data	Byte21 Data	Byte22 Data	Byte23 Data	Byte24 Data
Para3	Para3	Para4	Para4	Para5	Para5	Para6	Para6	Para7	Para7	Para8	Para8
240	0	0	1	44	1	124	1	0	2	88	2
PIX3=240		PIX4=256		PIX5=300		PIX6=380		PIX7=512		PIX8=600	

Byte25 Data	Byte26 Data	Byte27 Data	Byte28 Data	Byte29 Data	Byte30 Data	Byte31 Data	Byte32 Data	Byte33 Data	Byte34 Data	Byte35 Data	Byte36 Data
Para9	Para9	Para10	Para10	Para11	Para11	Para12	Para12	Para13	Para13	Para14	Para14
168	2	170	2	188	2	188	2	198	2	208	2
PIX9=680		PIX10=682		PIX11=700		PIX12=700		PIX13=710		PIX14=720	

Byte37 Data	Byte38 Data	Byte39 Data	Byte40 Data	Byte41 Data	Byte42 Data	Byte43 Data	Byte44 Data	Byte45 Data	Byte46 Data	Byte47 Data	Byte48 Data
Para15	Para15	Para16	Para16	Para17	Para17	Para18	Para18	Para19	Para19	Para20	Para20
34	3	32	3	32	3	22	3	19	3	20	3
PIX15=802		PIX16=800		PIX17=800		PIX18=790		PIX19=787		PIX20=788	



Byte509 Data	Byte510 Data	Byte511 Data	Byte512 Data	Byte513 Data	Byte514 Data	Byte515 Data	Byte516 Data	Byte517 Data	Byte518 Data	Byte519 Data	Byte520 Data
Para251	Para251	Para252	Para252	Para253	Para253	Para254	Para254	Para255	Para255	Para256	Para256
124	1	44	1	0	1	240	0	220	0	200	0
PIX251=380		PIX252=300		PIX253=256		PIX254=240		PIX255=220		PIX256=200	

With <ARG = 0> (STATISTICS DATA BUFFER) and <ARG = 3> (CURRENT SCAN BUFFER) the current counter (SCAN-COUNTER) also is sent in the last data word (byte 519, byte 520).

4.4.5 ORDER=11: Activate SINGLE SHOT MEASUREMENT at L-LAS sensor

< ORDER = 11 >

Activate a single measurement data scan at the sensor. The number of scans (single measurements) is set in the argument <ARG> of the header frame.

DATA FRAME PC → Sensor (8 bytes)

ARG = NUMBER OF SINGLE MEASUREMENTS (100 ... 5000)

Byte1 Header	Byte2 Header	Byte3 Header	Byte4 Header	Byte5 Header	Byte6 Header	Byte7 Header	Byte8 Header
0x55	<order>	<ARG> (lo byte)	<ARG> (hi byte)	<LEN> (lo byte)	<LEN> (hi byte)	CRC8 (Data)	CRC8 (Header)
85 (dec)	11	232	3	0	0	170	67
		ARG = 1000		LEN = 0			

DATA FRAME Sensor → PC (8 bytes)

Byte1 Header	Byte2 Header	Byte3 Header	Byte4 Header	Byte5 Header	Byte6 Header	Byte7 Header	Byte8 Header
0x55	<order>	<ARG> (lo byte)	<ARG> (hi byte)	<LEN> (lo byte)	<LEN> (hi byte)	CRC8 (Data)	CRC8 (Header)
85 (dec)	11	0	0	0	0	170	67
		ARG = 0		LEN = 0			

4.4.6 ORDER=12: Activate WHITE BALANCE PROCEDURE at sensor

< ORDER = 12 >

Activate white balancing at the sensor. The storage location is set in the argument <ARG> of the header frame.

DATA FRAME PC → Sensor (8 bytes)

ARG: 0=RAM, 1=EEPROM

Byte1 Header	Byte2 Header	Byte3 Header	Byte4 Header	Byte5 Header	Byte6 Header	Byte7 Header	Byte8 Header
0x55	<order>	<ARG> (lo byte)	<ARG> (hi byte)	<LEN> (lo byte)	<LEN> (hi byte)	CRC8 (Data)	CRC8 (Header)
85 (dec)	12	0	0	0	0	170	67
		ARG = 0		LEN = 0			

DATA FRAME Sensor → PC (8 bytes)

Byte1 Header	Byte2 Header	Byte3 Header	Byte4 Header	Byte5 Header	Byte6 Header	Byte7 Header	Byte8 Header
0x55	<order>	<ARG> (lo byte)	<ARG> (hi byte)	<LEN> (lo byte)	<LEN> (hi byte)	CRC8 (Data)	CRC8 (Header)
85 (dec)	12	0	0	0	0	170	67
		ARG = 0		LEN = 0			

4.4.7 ORDER=12: Activate EVALUATION PROGRAM at L-LAS sensor

< ORDER = 16 >

Activate the current evaluation program at the sensor. The program number (0 to 15) is sent in the argument.

DATA FRAME PC → Sensor (8 bytes)

ARG = PROG-NO

Byte1 Header	Byte2 Header	Byte3 Header	Byte4 Header	Byte5 Header	Byte6 Header	Byte7 Header	Byte8 Header
0x55	<order>	<ARG> (lo byte)	<ARG> (hi byte)	<LEN> (lo byte)	<LEN> (hi byte)	CRC8 (Data)	CRC8 (Header)
85 (dec)	16	1	0	0	0	170	65
		ARG=1		LEN=0			

DATA FRAME Sensor → PC (8 bytes)

Byte1 Header	Byte2 Header	Byte3 Header	Byte4 Header	Byte5 Header	Byte6 Header	Byte7 Header	Byte8 Header
0x55	<order>	<ARG> (lo byte)	<ARG> (hi byte)	<LEN> (lo byte)	<LEN> (hi byte)	CRC8 (Data)	CRC8 (Header)
85 (dec)	16	1	0	0	0	170	65
		ARG=1		LEN=0			

4.4.8 ORDER=26: Send TEACH VECTOR ENTRY to L-LAS sensor

< ORDER = 26 >

The teach table of the control unit for the evaluation of jets contains up to 16 entries (programs). These entries in the teach table are used for edge searching by way of the intensity distribution over the individual pixels at the line sensor (see manual). Every entry in the teach table (teach vector) has a length of 16 words (32 bytes).

Currently only the first 7 entries in the teach vector are used, but column entries 8 to 16 of the teach vector nevertheless must be sent (total of 40 bytes = 8 header bytes + 32 data bytes).

Example:

Teach table program ARG = 1.

The first 7 columns of the teach table are processed in the L-LAS control unit.

The remaining columns 8-16 of the teach table nevertheless must be sent (assigned 0).

	A1	A2	B1	B2	EVM_A	EVM_B	DIR	VTHD	VAL_A	VAL_B	TOL_A	TOL_B			
P1	1	-1	1	-1	CENT	▼	DIST	▼	L	▼	20	800	230	25	20

DIR: 0=LEFT, 1=RIGHT

EVALMODE: 0=OFF, 1=POS, 2=CENTER, 3=DISTANCE, 4=CENTER, 5=DMAX, 6=AREA, 7=SYMMETRY

DATA FRAME PC → Sensor (8 bytes +32 bytes)

ARG = TEACH VECTOR LINE INDEX 0 ... 15

Byte1 Header	Byte2 Header	Byte3 Header	Byte4 Header	Byte5 Header	Byte6 Header	Byte7 Header	Byte8 Header	Byte9 Data	Byte10 Data	Byte11 Data	Byte12 Data
0x55	<order>	<ARG> (lo byte)	<ARG> (hi byte)	<LEN> (lo byte)	<LEN> (hi byte)	CRC8 (Data)	CRC8 (Header)	Data1 (lo byte)	Data1 (hi byte)	Data2 (lo byte)	Data2 (hi byte)
85 (dec)	26	1	0	32	0	XXX	50	1	0	-1	-1
		ARG=1		LEN=32				A1 = 1		A2 = -1	

Byte13 Data	Byte14 Data	Byte15 Data	Byte16 Data	Byte17 Data	Byte18 Data	Byte19 Data	Byte20 Data	Byte21 Data	Byte22 Data	Byte23 Data	Byte24 Data
Data3	Data3	Data4	Data4	Data5	Data5	Data6	Data6	Data7	Data7	Data8	Data8
1	0	-1	-1	2	0	3	0	0	0	20	0
B1 = 1		B2 = -1		EVM A = 2		EVM B = 3		DIR = 0		VTHD=20	

Byte25 Data	Byte26 Data	Byte27 Data	Byte28 Data	Byte29 Data	Byte30 Data	Byte31 Data	Byte32 Data	Byte33 Data	Byte34 Data	Byte35 Data	Byte36 Data
Data9	Data9	Data10	Data10	Data11	Data11	Data12	Data12	Data13	Data13	Data14	Data14
32	3	230	0	25	0	20	0	0	0	0	0
VAL A=800		VAL B=230		TOL A=25		TOL B=20		0		0	

Byte37 Data	Byte38 Data	Byte39 Data	Byte40 Data
Data15	Data15	Data16	Data16
0	0	0	0
0		0	

DATA FRAME Sensor → PC (8 bytes)

Byte1 Header	Byte2 Header	Byte3 Header	Byte4 Header	Byte5 Header	Byte6 Header	Byte7 Header	Byte8 Header
0x55	<order>	<ARG> (lo byte)	<ARG> (hi byte)	<LEN> (lo byte)	<LEN> (hi byte)	CRC8 (Data)	CRC8 (Header)
85 (dec)	26	0	0	0	0	170	50
		ARG=0		LEN=0			

The argument of the header frame that is sent back from the control unit shows the status of data exchange:

ARG = 0 , no error

ARG = - 105, data transmission error

4.4.9 ORDER=30: Activate Measurement-System-Analysis (MSA) at L-LAS sensor

< ORDER = 30 >

Activate the measuring system analysis (MSA) on the sensor, the program number (0 to 15) is transferred in the argument. The evaluation program = 15 is used as the standard value for the MSA. The MSA is carried out in SINGLE-SHOT mode.

DATA FRAME PC → Sensor (8-Bytes)

ARG = PROG-NO = 55

Byte1 Header	Byte2 Header	Byte3 Header	Byte4 Header	Byte5 Header	Byte6 Header	Byte7 Header	Byte8 Header
0x55	<order>	<ARG> (lo byte)	<ARG> (hi byte)	<LEN> (lo byte)	<LEN> (hi byte)	CRC8 (Data)	CRC8 (Header)
85 (dec)	30	15	0	0	0	170	240
		ARG = 15		LEN=0			

DATA FRAME Sensor → PC (8 Bytes)

Byte1 Header	Byte2 Header	Byte3 Header	Byte4 Header	Byte5 Header	Byte6 Header	Byte7 Header	Byte8 Header
0x55	<order>	<ARG> (lo byte)	<ARG> (hi byte)	<LEN> (lo byte)	<LEN> (hi byte)	CRC8 (Data)	CRC8 (Header)
85 (dec)	30	0	0	0	0	170	159
		ARG=0		LEN=0			

Die Messwerte, die nach Aktivierung der MSA generiert wurden (SINGLE-SHOT Modus), können anschließend mit **<ORDER = 8> vom Sensor ausgelesen** werden.

The measured values that were generated after activating the MSA (SINGLE-SHOT mode) can then be read out with **<ORDER = 8>** from the sensor.

DATA FRAME PC → Sensor (8-Bytes)

ARG = 255

Byte1 Header	Byte2 Header	Byte3 Header	Byte4 Header	Byte5 Header	Byte6 Header	Byte7 Header	Byte8 Header
0x55	<order>	<ARG> (lo byte)	<ARG> (hi byte)	<LEN> (lo byte)	<LEN> (hi byte)	CRC8 (Data)	CRC8 (Header)
85 (dec)	30	255	0	0	0	170	86
		ARG = 255		LEN=0			

DATA FRAME Sensor → PC (8 Bytes)

Byte1 Header	Byte2 Header	Byte3 Header	Byte4 Header	Byte5 Header	Byte6 Header	Byte7 Header	Byte8 Header
0x55	<order>	<ARG> (lo byte)	<ARG> (hi byte)	<LEN> (lo byte)	<LEN> (hi byte)	CRC8 (Data)	CRC8 (Header)
85 (dec)	30	0	0	0	0	170	159
		ARG=0		LEN=0			